

HYDRUS 2300V PANEL
 AUTO-START
 ON PRESSURE / PRESSURE
 SHUTDOWN OPTION
 P/N: 3052300626

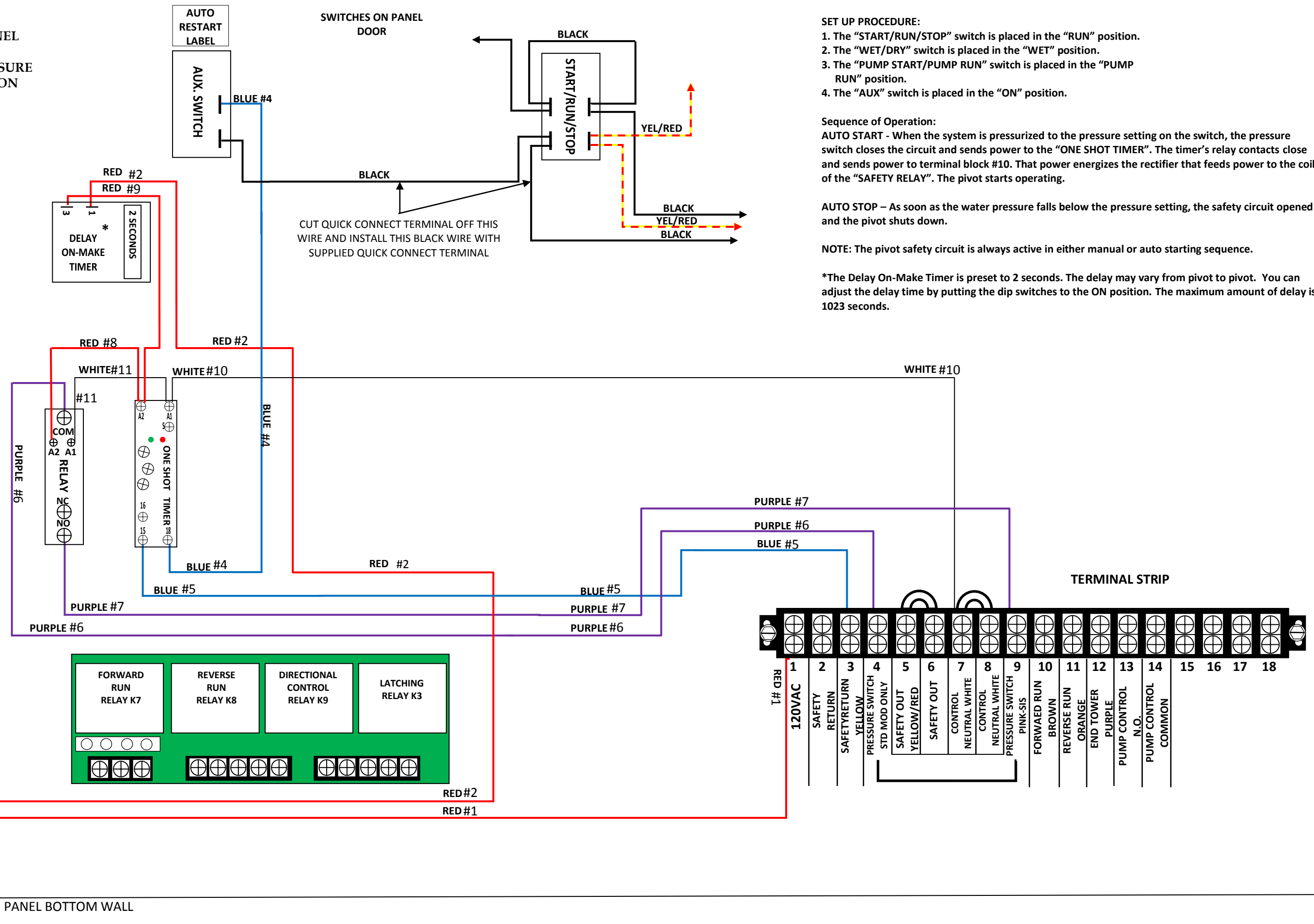

SET UP PROCEDURE:

1. The "START/RUN/STOP" switch is placed in the "RUN" position.
2. The "WET/DRY" switch is placed in the "WET" position.
3. The "PUMP START/PUMP RUN" switch is placed in the "PUMP RUN" position.
4. The "AUX" switch is placed in the "ON" position.

Sequence of Operation:

AUTO START - When the system is pressurized to the pressure setting on the switch, the pressure switch closes the circuit and sends power to the "ONE SHOT TIMER". The timer's relay contacts close and sends power to terminal block #10. That power energizes the rectifier that feeds power to the coil of the "SAFETY RELAY". The pivot starts operating.

AUTO STOP - As soon as the water pressure falls below the pressure setting, the safety circuit opened and the pivot shuts down.

NOTE: The pivot safety circuit is always active in either manual or auto starting sequence.

*The Delay On-Make Timer is preset to 2 seconds. The delay may vary from pivot to pivot. You can adjust the delay time by putting the dip switches to the ON position. The maximum amount of delay is 1023 seconds.