

**HYDRUS 2300 AUTO-START
ON PRESSURE / PRESSURE
SHUTDOWN OPTION PIVOT.
P/N: 3606**

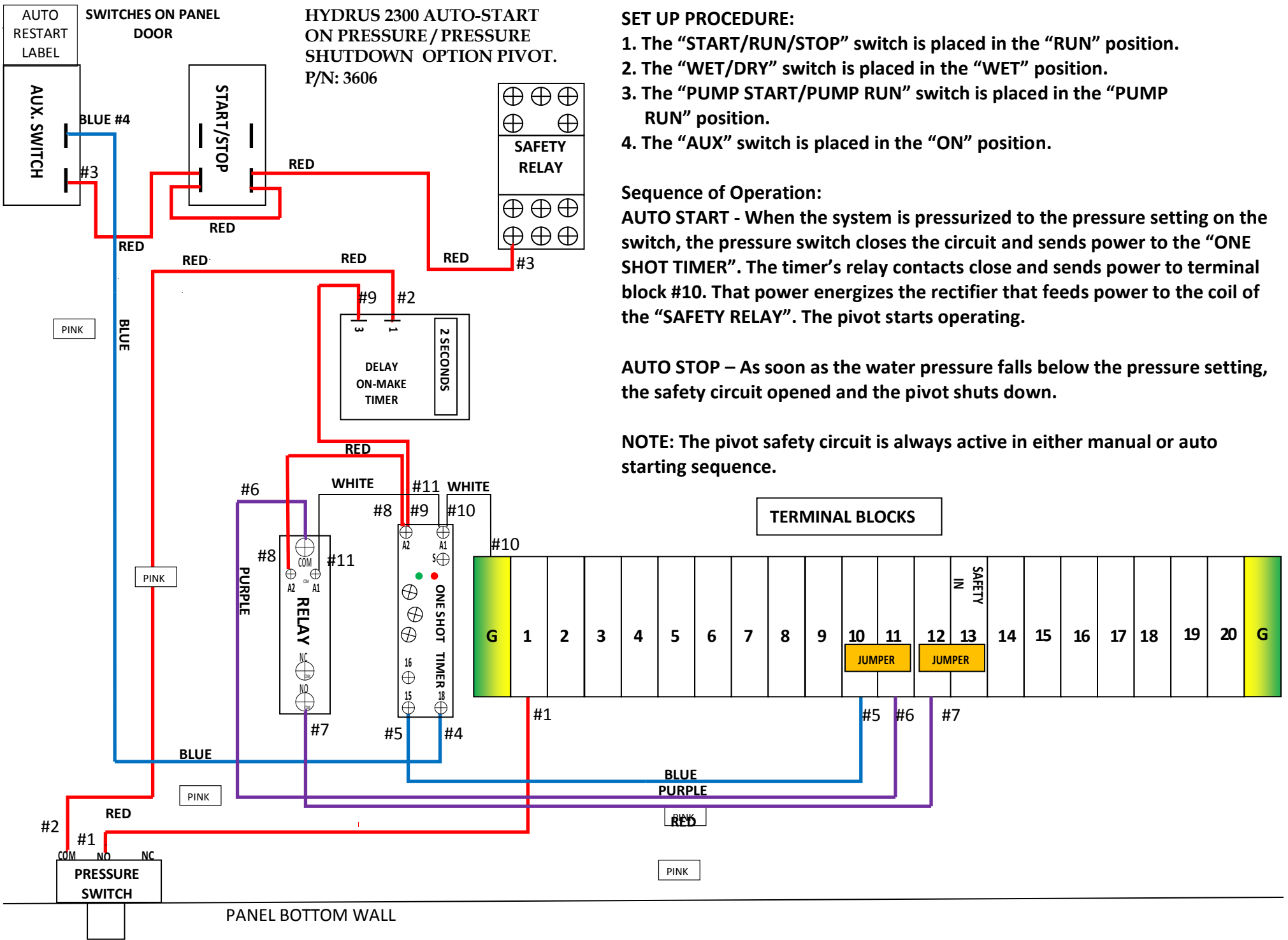

SET UP PROCEDURE:

1. The "START/RUN/STOP" switch is placed in the "RUN" position.
2. The "WET/DRY" switch is placed in the "WET" position.
3. The "PUMP START/PUMP RUN" switch is placed in the "PUMP RUN" position.
4. The "AUX" switch is placed in the "ON" position.

Sequence of Operation:

AUTO START - When the system is pressurized to the pressure setting on the switch, the pressure switch closes the circuit and sends power to the "ONE SHOT TIMER". The timer's relay contacts close and sends power to terminal block #10. That power energizes the rectifier that feeds power to the coil of the "SAFETY RELAY". The pivot starts operating.

AUTO STOP - As soon as the water pressure falls below the pressure setting, the safety circuit opened and the pivot shuts down.

NOTE: The pivot safety circuit is always active in either manual or auto starting sequence.